

**GHMR/L** : CUT-GRIP toolholders for shallow radial and axial grooving. Light turning, small depth of cut ( $a_p=0.1-0.5$  mm), and small feed ( $f=0.1$  mm/rev).

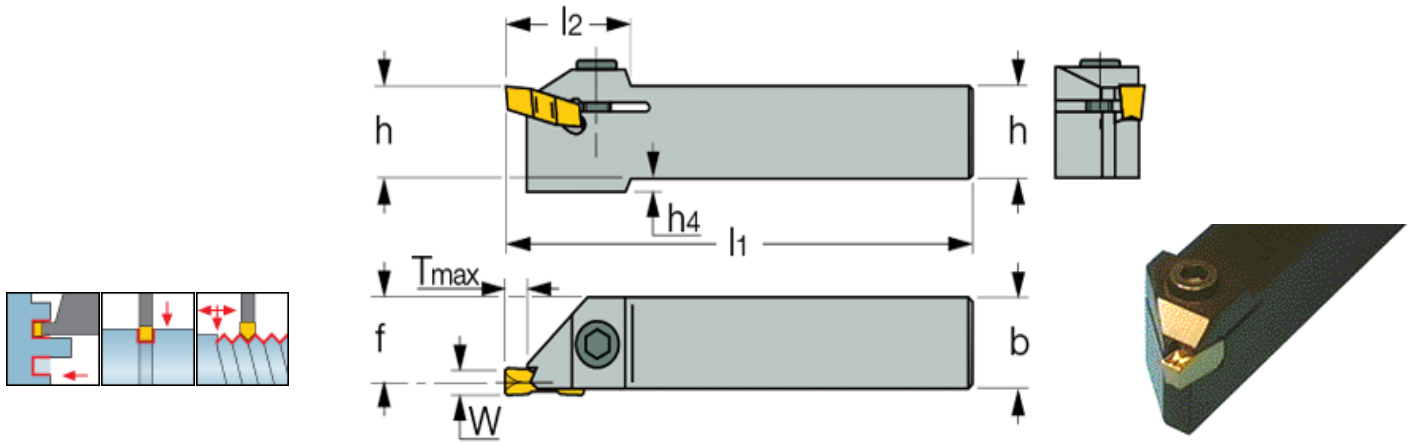

Designation	W max	Tmax-r	Tmax-a	h	b	l1	l2	f	h4
GHML 12	4	4.8	4.8	12	12	110	25	10.8	4
GHMR 12	4.8	4.8	4.8	12	12	110	25	10.8	4
GHML 16	4.8	4.8	4.8	16	16	115	25	14.5	-
GHMR 16	4.8	4.8	4.8	16	16	115	25	14.5	-
GHML 16-3 ST	5	4.8	4.8	16	16	78	25	15	-
GHMR 16-3 ST	5	4.8	4.8	16	16	78	25	15	-
GHML 20	6.4	4.8	4.8	20	20	125	25	18.5	-
GHMR 20	6.4	4.8	4.8	20	20	125	25	18.5	-
GHML 25	6.4	4.8	4.8	25	25	140	25	23.5	-
GHMR 25	6.4	4.8	4.8	25	25	140	25	23.5	-
GHML 32	6.4	4.8	4.8	32	32	150	25	30.2	-
GHMR 32	6.4	4.8	4.8	32	32	150	25	30.2	-

For insert clamping instructions, click on "More Info".