

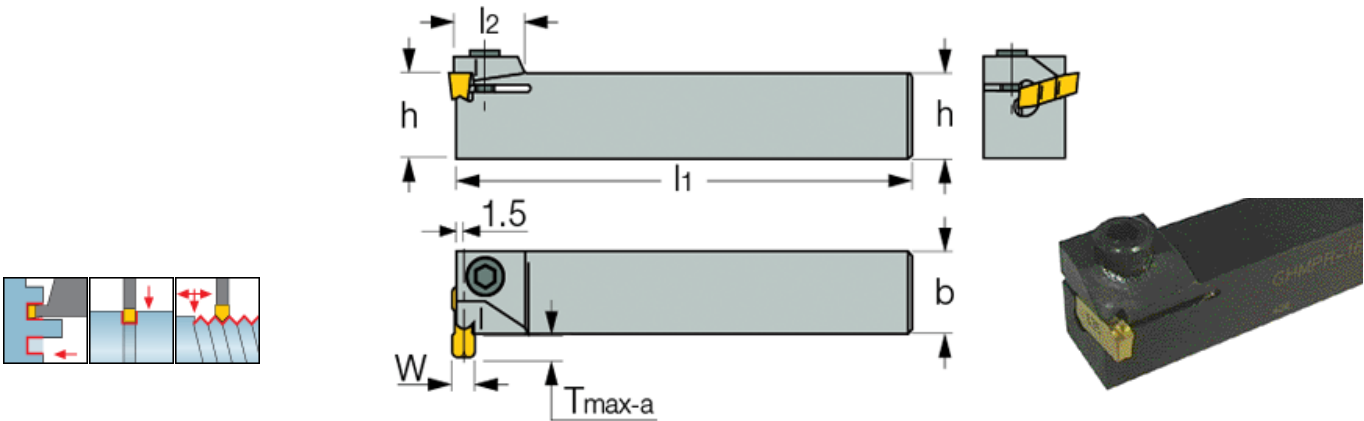

GHMPR/L : CUT-GRIP, perpendicular toolholders for shallow radial and axial grooving. Light turning, small depth of cut ($a_p=0.1-0.5$ mm), and small feed ($f=0.1$ mm/rev).



Designation	W max	Tmax-r	Tmax-a	h	b	l1	l2
GHMPL 16	4.8	4.8	4.8	16	16	110	17
GHMPR 16	4.8	4.8	4.8	16	16	110	17
GHMPL 20	6.4	4.8	4.8	20	20	120	17
GHMPR 20	6.4	4.8	4.8	20	20	120	17
GHMPL 25	6.4	4.8	4.8	25	25	135	17
GHMPR 25	6.4	4.8	4.8	25	25	135	17

For insert clamping instructions, click on "More Info".