

GHIUR/L-C-22.5A-8V : Bars for internal and face machining of aluminum wheels

Right-hand shown

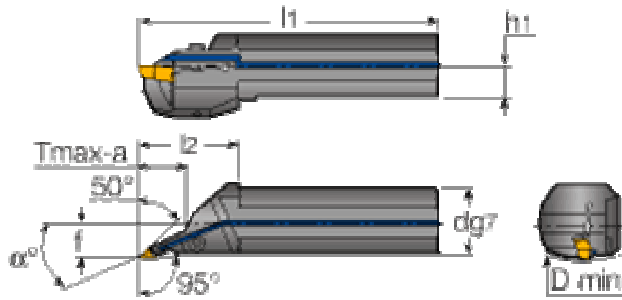
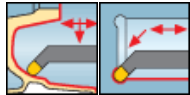

Designation	W	d	D min	T max-a	l1	l2	h1	f	a?/b>
GHIUL 40C-22.5A-8V	8	40	300	28.5	250	60	18	21	22.5
GHIUR 40C-22.5A-8V	8	40	300	28.5	250	60	18	21	22.5