

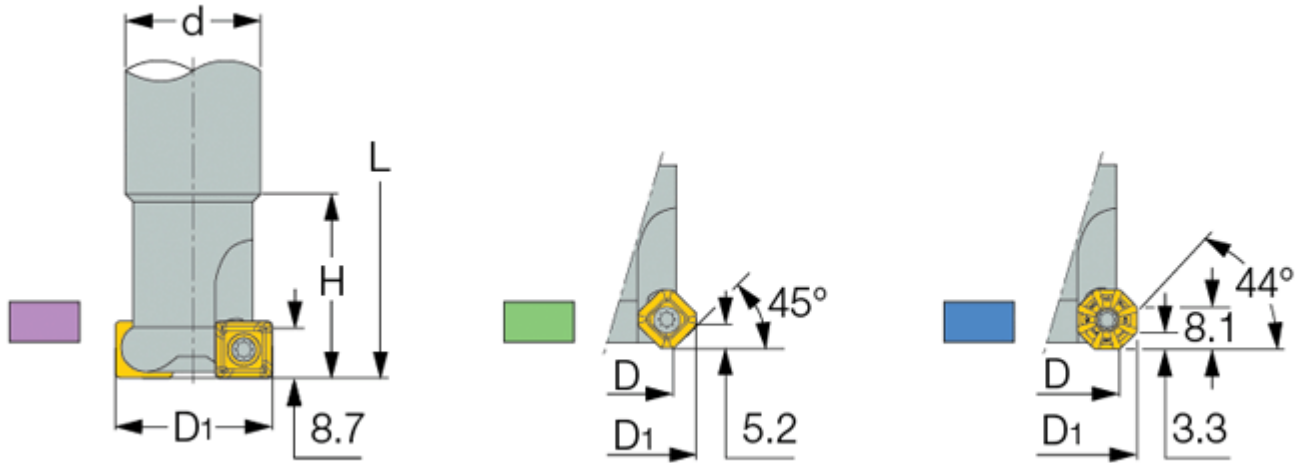

ECM : CHAMMILL endmills for four insert shapes. Part of the CHAMELEON multi-functional line.



The displayed data refers to S90MT inserts. For other combinations see "more info".



Designation	D1	Z	H	Rd°	L	d	Kg	Shank
ECM D032-W25-11	32.0	3	40.00	10.3	100.00	25.00	0.35	W
ECM D040-W32-11	40.0	4	40.00	5.9	105.00	32.00	0.62	W

The displayed data refers to S90MT inserts. For other combinations see "More Info".
For adaptation click on "More Info".