

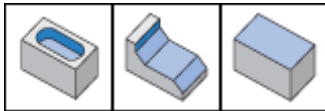

F45E (Endmill) : 45° endmills with SEKN/R 12... inserts.

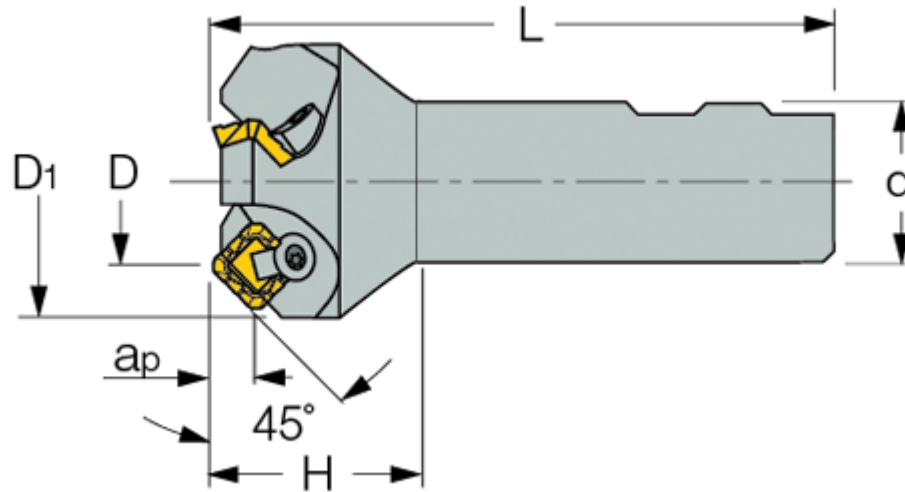

Designation	D	D1	H	L	Z	ap	d	Shank	Kg
F45E D 25-C20	25.00	38.4	32.0	92.00	2	6.50	20.00	C	0.52
F45E D 32-W25	32.00	45.4	32.0	100.00	3	6.50	25.00	W	0.42
F45E D 38/1.50-R8	38.00	56.5	38.1	140.00	3	6.50	-	R8	0.75
F45E D 40-W25	40.00	58.5	32.0	97.00	3	6.50	25.00	W	0.63
F45E D 50/2.0-R8	50.00	67.2	38.1	140.00	4	6.50	-	R8	0.91
F45E D 63/2.5-R8	63.00	81.2	38.1	140.00	5	6.50	-	R8	1.17
F45E D 80-S.....JPN	80.00	98.0	40.0	140.00	6	6.50	32.00	C	1.88

For adaptation, click on "More Info".