

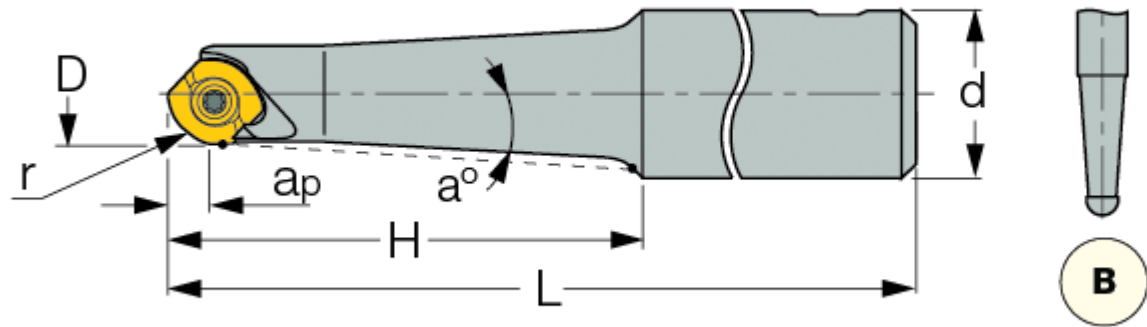

CM D10 : Ball nose endmills D=10 mm (HELIBALL).



Designation	D	r	ap	H	L	a°/b°	d	Shank	Type	Kg
CM D10-A-W12	10.00	5.00	6.40	25.00	90.00	0	12.00	W	A	0.07
CM D10-B-C16	10.00	5.00	6.40	50.00	150.00	3	16.00	C	B	0.20

For adaptation, click on "More Info".