

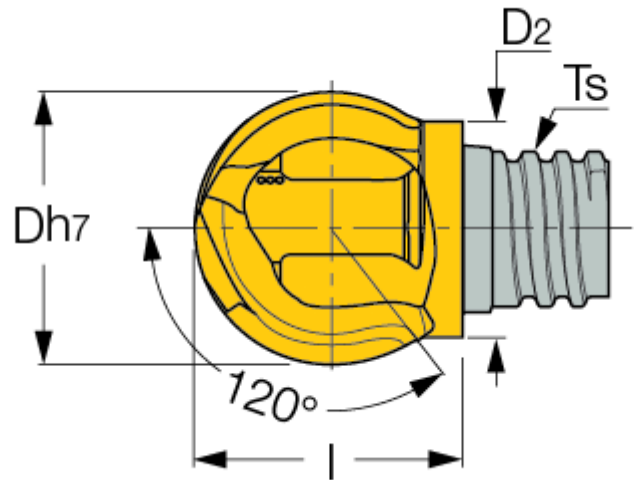

MM HBR : MULTI-MASTER, high accuracy (h7 milling head diameter), may be used for both roughing and precision finishing applications. It can be used on hardened steel.



Economical solution



Designation	D	Flute	Ts	D2	l	Grade
MM HBR100-2T05	10.00	2	T05	7.60	10.10	IC908
MM HBR120-2T06	12.00	2	T06	9.60	11.60	IC908
MM HBR.500-2T06	12.70	2	T06	9.60	12.20	IC908
MM HBR160-2T08	16.00	2	T08	11.50	15.40	IC908
MM HBR200-2T10	20.00	2	T10	15.20	18.50	IC908
MM HBR250-2T12	25.00	2	T12	18.30	23.20	IC908
MM HBR1.00-2T12	25.40	2	T12	18.30	23.40	IC908

For Clamping keys (should be ordered separately), tightening torques and clamping instructions, click on "More Info".

Do not apply lubricant to the threaded connection.